

Shooting Board

3-5° Top back-off

Front 45° or 90°

Cutters 2 off HSS 26 x 6 mm

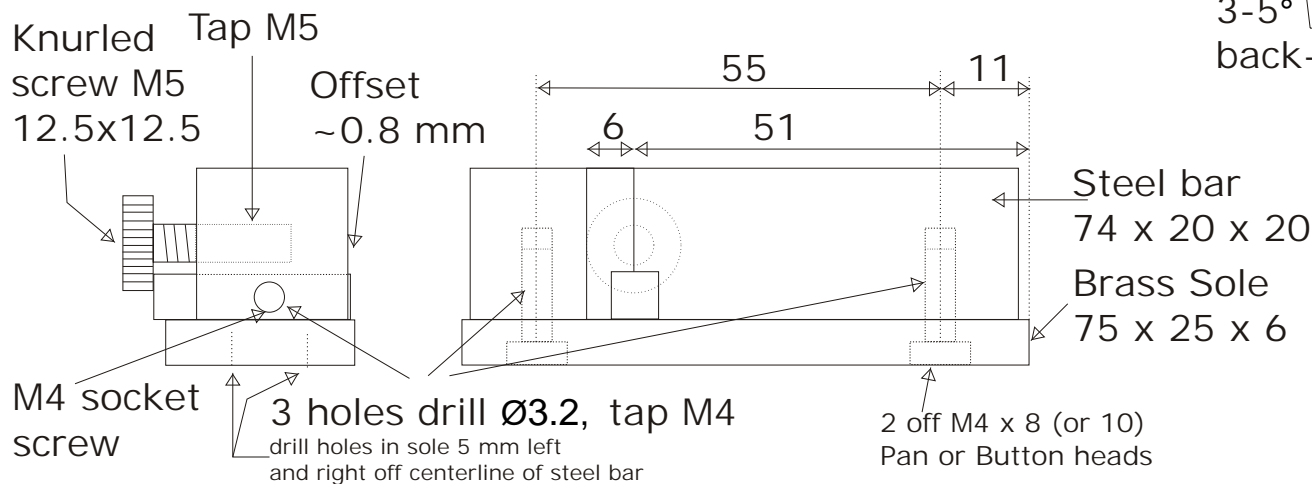

Plane (2 off)

<h2>Shooting Board and Planes</h2>	
Design & Development : Peter Clark	
Artwork: Henk Oversloot	dimensions in mm
 <h1>Scale Association</h1>	